



# Auto Compact Air Inflator

# Problem

omobloc  
by mbl

**Too big?**



**Too hard?**



**Compact !  
Easy!**



# Features

omoblc  
by mbl

- Size 234x57x45mm, small enough to fit in your pocket or backpack.
- Fast inflation, flat tyre or ball
- Single button operation
- Up to 150PSI = 10.3Bar
- Rechargeable, no battery is needed



Quick Inflation



Small & Smart



LED Display



Ultra High Pressure



LED Light



# Specification

Item NO

TYREIO









Size	234*57*45(mm)
Weight	430g
Battery	2600mAh 7.4V
Work current	1-6A
Charging mode	Type_c
Charging time	2 hours
Max inflating pressure	150PSI & 10.3BAR
Operation temperature	-10°C ~ +60°C

# Scenario and Valve



	Reference pressure	Time from empty	Frequency from empty
Car	2.3–2.5bar	8–12min	2–3 (205 55R17)
Road Bike	100–120psi	2–3min	8–12 (700*23C)
Mountain Bike	30–50psi	2–3min	12–18 (26*1.95)
Motorcycle	30–50psi	2–3min	8–12
Basketball	7–9psi	0.5–1min	30–40

Inflatable Interface			
Valve Type			
	American valve	French valve	Ball



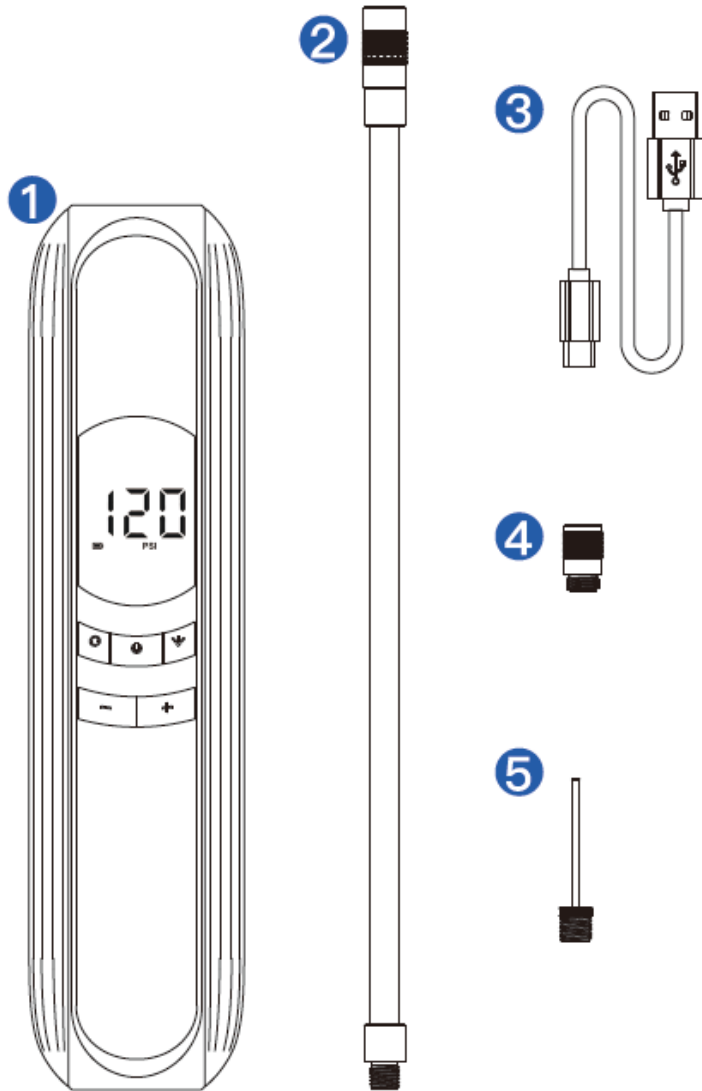

# Packing List

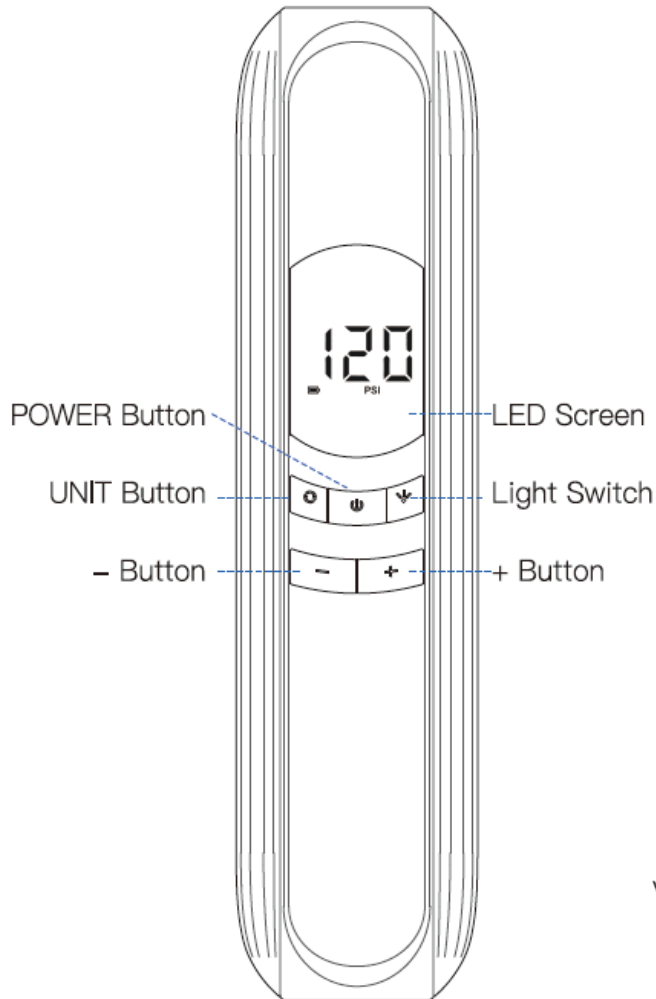

- ① Inflator
- ② Air Tube
- ③ Type\_C Charging Cable
- ④ Valve Converter
- ⑤ Ball Converter

# Details



	Press	Long Press
	Start / Stop inflating	Turn on / off power
	Choose mode	Choose unit
	Turn on / off lighting (Screen is on)	Turn on / off lighting (Screen is off)
	Increase pressure	Quick increase
	Reduce pressure	Quick reduce



# Using Instruction

01. Long press the POWER Button to turn on the power. The LED will display the current pressure.

02. Long press the UNIT button can switch the units PSI and BAR. If short press, you can switch between 5 modes of use: custom, car, motorcycle, bicycle, and basketball. Commonly used air pressure values are preset in each mode.

03. The + Button and – Button are used to adjust the preset air pressure value, long press them can quickly adjust. (In the custom mode, A7 will memorize the pressure value last set)

04. Pressing the POWER Button can start inflating. Pressing it again can pause/continue. It will stop automatically when it reaches the target pressure.





# About Charging

01. For the first time to use or a long time no use, please charge the inflator before using.
02. The charging indicator will turn red during the charging and turn green when the battery is fully charged.
03. Usually, the air inflator should be charged every two months even though it was not used. if you do not charge it for a long time, the battery will be over-discharged and lead to battery damaged.

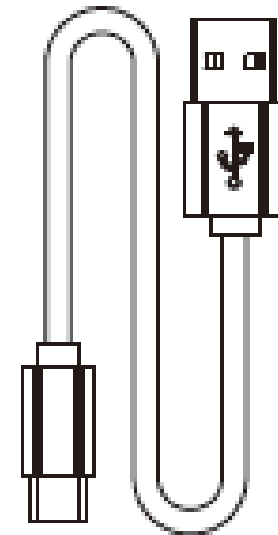

# Attention

01. It's normal that the inflator becomes hot after working more than 1min. Please don't touch the hot part of the air tube!

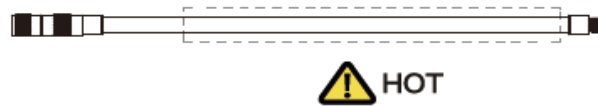

02. Please check the inflator before inflating. If find any exception, don't use it.

03. If find any abnormal sounds or excessive temperatures during the inflation, please stop using it immediately.

04. Please ensure the smooth flow of air during the inflation.

05. The compressor in the inflator may produce electric sparks at work. Please keep it away from flammable and explosive objects.

06. Don't leave to prevent accidents during inflating.

07. After long-time using, both the inflator and the air tube will become hot. Please take a break before using it again.

08. Please try to avoid silt invasion, soaking and bad fall.

09. Harsh chemicals, cleaning agents, detergents and other chemicals are forbidden to be used during the cleaning.

10. Don't store the inflator in a cold, hot and humid place.

11. Children are forbidden to use the inflator. Please keep it away from children.

12. Don't inflate the air into the mouth, ear, eye, etc. of the persons or animals.

13. Inflating is not recommended during the charging.

14. When the inflator is working, because the electric current is large, the battery power is low, only for reference.

omobtc  
by mbl

**THANK YOU**